

EK-Quantum Momentum² Aorus Z690 Master D-RGB

MONOBLOCK

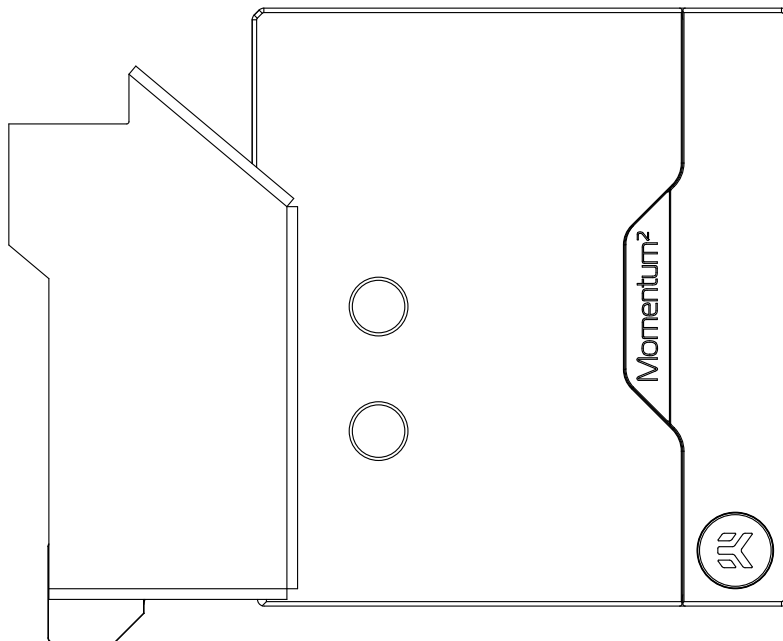

This product is intended for installation only by expert users. Please consult with a qualified technician for installation. Improper installation may result in damage to your equipment. EK Water Blocks assumes no liability whatsoever, expressed or implied, for the use of these products, nor their installation. The following instructions are subject to change without notice. Please visit our website at www.ekwb.com for updates. Before installation of this product please read the important notice, disclosure, and warranty conditions printed on the back of the box.

Before you start using this product, please follow these basic guidelines:

Please carefully read the manual thoroughly before beginning the installation process!

Please remove your motherboard from the computer to assure the safest mounting process in order to prevent any possible damages to your CPU and/or motherboard's circuit board (PCB).

The EK-Fittings require only a small amount of force to screw them firmly in place since the liquid seal is ensured by the rubber o-ring gaskets.

The use of quality, market-proven corrosion inhibiting coolants is always strongly recommended for any liquid cooling system.

TABLE OF CONTENTS

BOX CONTENTS	4
WATER BLOCK DIMENSIONS	5
TECHNICAL SPECIFICATIONS AND WATER BLOCK PARTS	6
PREPARING THE MOTHERBOARD	7
REMOVING THE BACKPLATE	7
REMOVING THE STOCK COOLER	8
CUTTING AND PLACING THERMAL PADS	9
APPLYING THERMAL COMPOUND	10
PREPARING THE WATER BLOCK FOR INSTALLATION	10
ATTACHING THE WATER BLOCK	11
CONNECTING THE D-RGB LED STRIP	13
TESTING THE LOOP	13
SUPPORT AND SERVICE	14
SOCIAL MEDIA	14

BOX CONTENTS

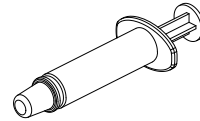
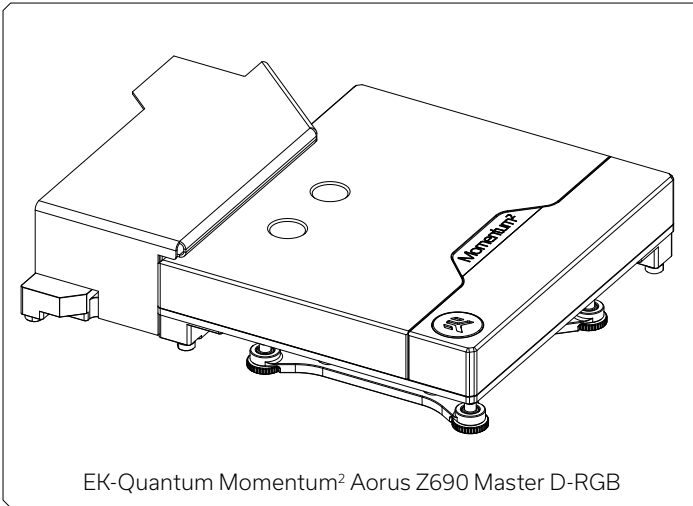

Thermal Grease (1 pc)



Allen Key 2.5 mm (1 pc)

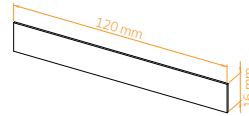

Thermal Pad F 1.0 mm (120x16) (4 pcs)



Allen Key 2 mm (1 pc)

WATER BLOCK DIMENSIONS

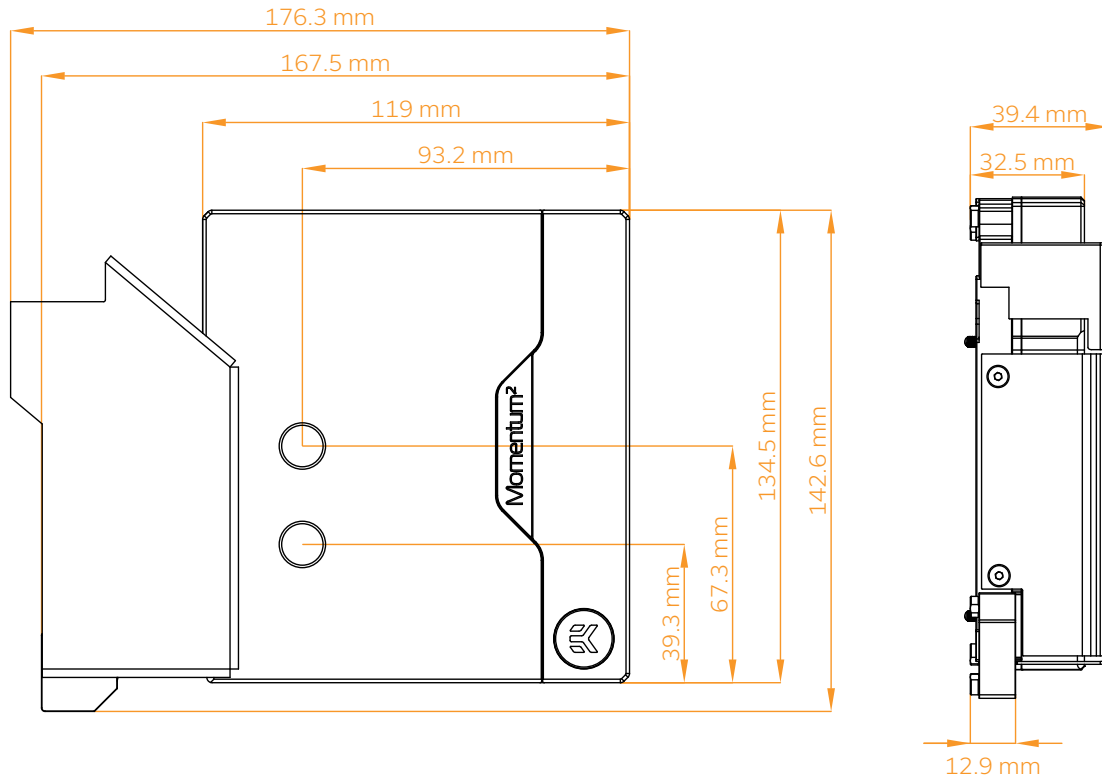

TECHNICAL SPECIFICATIONS AND WATER BLOCK PARTS

Technical Specification:

- Dimensions: (LxHxW) – 176.3 x 142.6 x 39.4 mm
- D-RGB cable length: 500 mm
- D-RGB LED count: 20
- D-RGB connector standard 3-pin (+5V, Data, Blocked, Ground)

Position	EAN	Description	Quantity
1	104977	Top plate (Plexi)	1
2	105225	Main O-ring 200 x 1.5 mm	1
3	105251	Mid plate Assembly	1
4	8208	Screw M3 x 8 DIN7991	4
5	104970	Mosfet (Black e.)	1
6	105038	I/O Cover stand	1
7	100258	Standoff M4/M2 x 2.5	5
8	104771	M3 x 20 DIN7991	4
9	8201N	Screw M3 x 10 DIN7991	8
10	104028	Coldplate (Nickel)	1
11	100500	M4 x 12 DIN7991	4
12	104650	Backplate Asseby	1
13	104773	Coldplate o-ring	1
14	104029	Jet plate	1
15	104974	Mosfet W (Nickel)	1
16	104972	Mosfet N (Nickel)	1
17	5163	OR 18 x 1.5 mm	1
18	5035	OR 26 x 1.5 mm	1
19	5158	OR 35 x 1.5 mm	1
20	10946	D-RGB Led strip	1
21	104976	Standout (Acetal)	1
22	100663	EK - Badge	1
23	104444	Mylar sticker	1

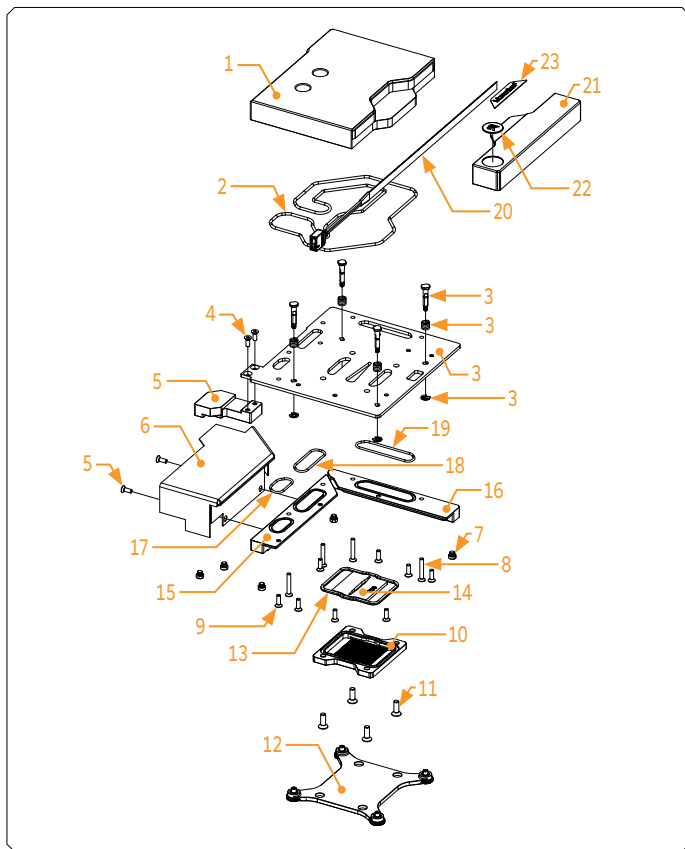

PREPARING THE MOTHERBOARD

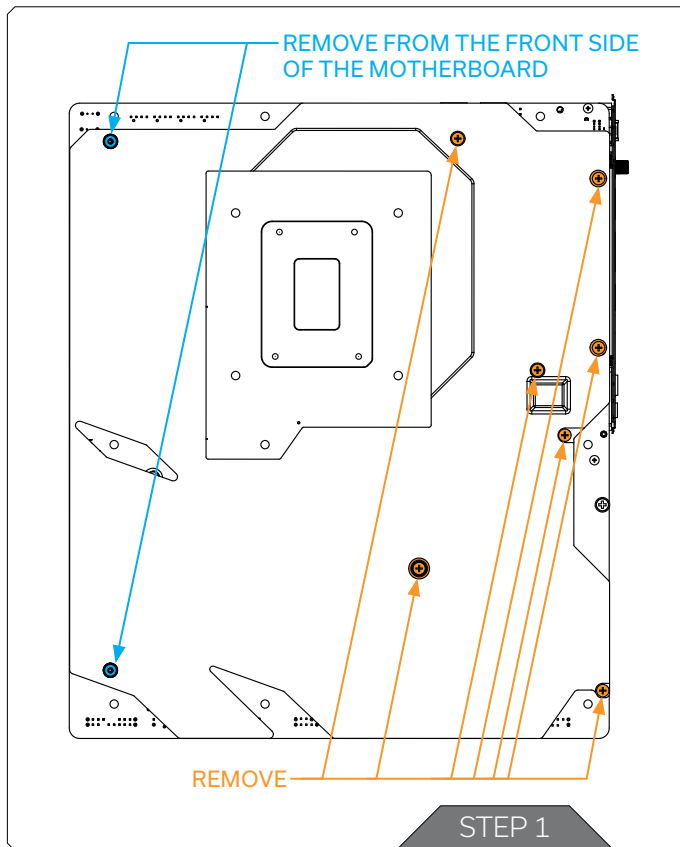

STEP 1 REMOVING THE BACKPLATE



Important! Before starting, make sure to have a clean, flat surface to work on. It is recommended to put foam or soft material to lay the motherboard and the water block on.

Remove the marked screws in order to detach the backplate from the motherboard.

After monoblock installation, the backplate can be reused.

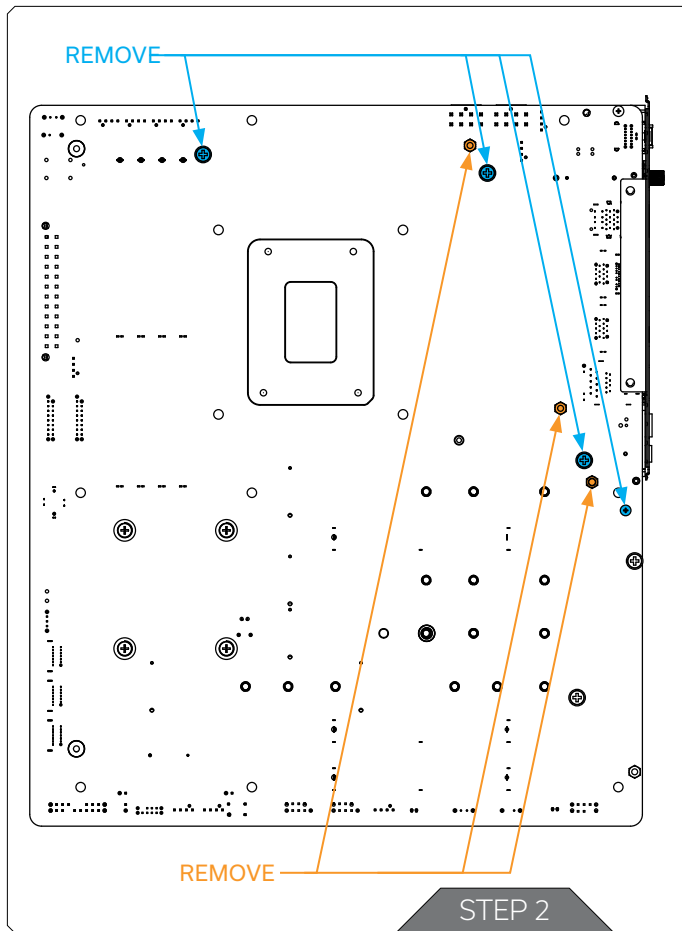

STEP 2 REMOVING THE STOCK COOLER

Additional four(4) screws and three(3) standoffs must be removed in order to remove the original stock cooler.

After removing the screws and standoffs, carefully detach the stock cooler and pre-applied thermal pads. EK provides replacement thermal pads with the water block (Chapter: CUTTING AND PLACING THERMAL PADS).

Save the screws and standoffs for later use (Chapter: ATTACHING THE WATER BLOCK).

CUTTING AND PLACING THERMAL PADS

Thermal Pad F - 1.0 mm (120 x 16 mm)

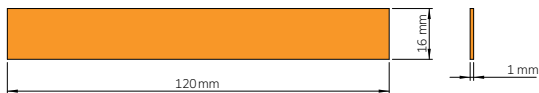

F1 Thermal Pad - 120 x 16 x 1.0 mm

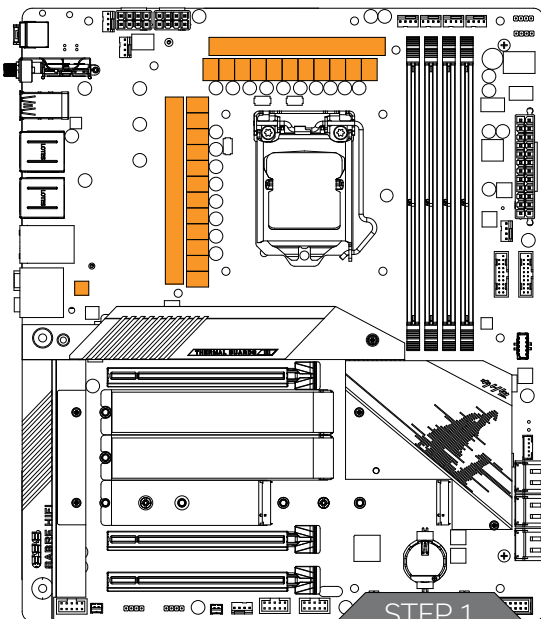

STEP 1

EK-Quantum Momentum² Aorus Z690 Master D-RGB water block comes with Thermal Pads that have to be cut into smaller pieces to cover all the regulation area (Mofset) on the motherboard. EK made sure to provide you with more than an adequate quantity of Thermal Pads to complete this Step.



Please remove the protective foil from both sides of the thermal pads prior to installation!

Replacement thermal pads:
Thermal Pad F 1.0 mm - (120 x 16 mm) EAN: 3830046996732

For this step, you will need:

Scissors

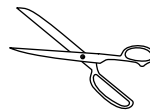

APPLYING THERMAL COMPOUND

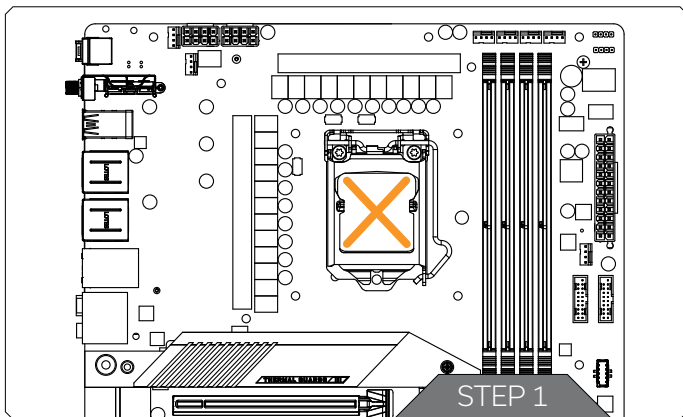

STEP 1

Apply the enclosed EK-TIM Ectotherm thermal grease (thermal compound) on the CPU heat spreader - IHS - as shown in the image. The layer of the thermal compound must be thin and even in thickness over the entire surface of the IHS.



The excessive or uneven application of thermal grease may lead to poor performance!

For this step, you will need:

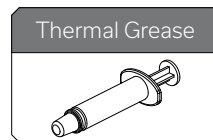

PREPARING THE WATER BLOCK FOR INSTALLATION

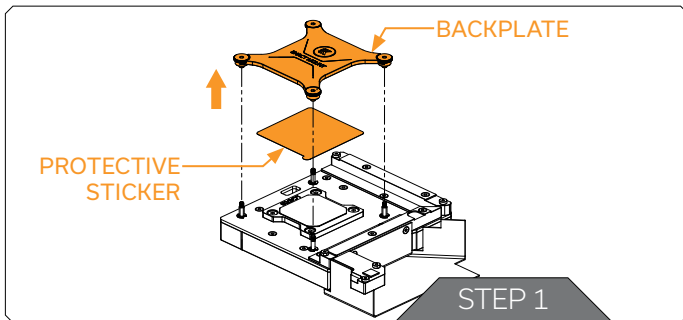

STEP 1

Unscrew four (4) Velocity² mounting nuts (turn them in an anticlockwise direction to unscrew). Remove the backplate and save it for later steps. After the backplate is removed, do not forget to peel off the protective sticker.

ATTACHING THE WATER BLOCK

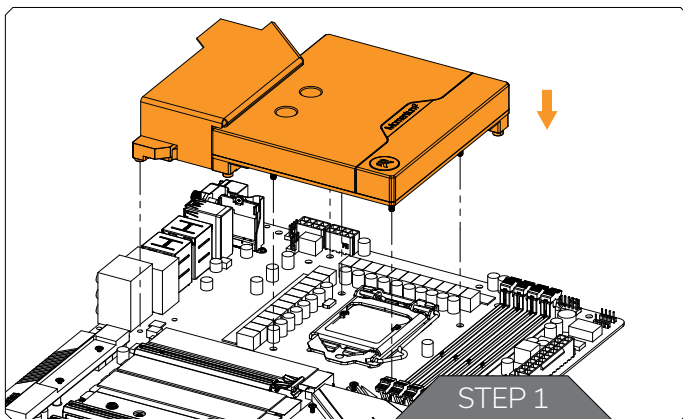

STEP 1

Carefully place the water block onto the motherboard and align four (4) mounting screws with four (4) holes on the motherboard. Hold the water block and the motherboard and turn them upside down.



Before placing the Water Block on the motherboard, make sure all the Thermal Pads are placed correctly! (Chapter: Cutting and placing thermal pads).

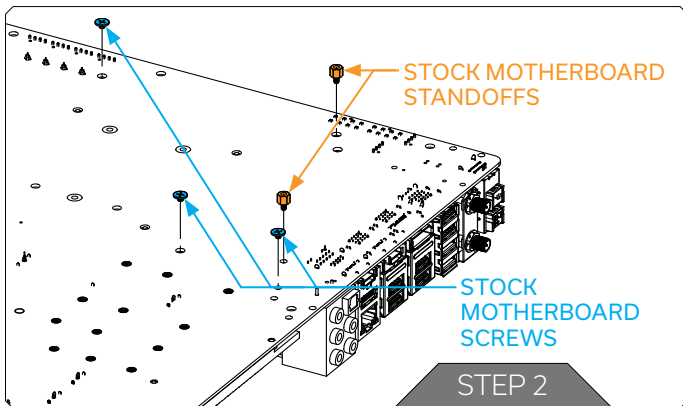

STEP 2

Secure the water block using three (3) stock motherboard screws and two (2) stock motherboard standoffs. Do not use excessive force!

EK recommends using the EK-Loop Torque Screwdriver - 0.6Nm: <https://www.ekwb.com/shop/ek-loop-torque-screwdriver-0-6nm>.

For this step you will need:

Phillips Head Screwdriver

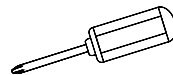

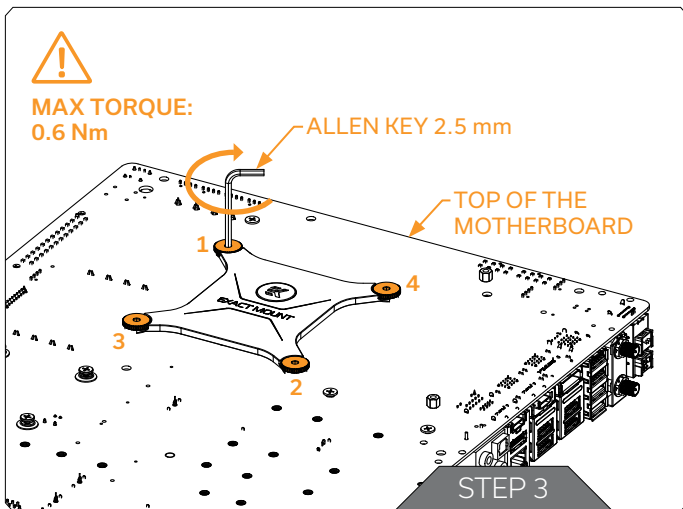

STEP 3

After securing the water block, the stored backplate must be attached to the backside of the motherboard using Allen Key 2.5 mm (shown in the picture) or EK-Loop Torque Screwdriver. Start fastening the backplate screws in a cross pattern. Do not tighten fully until all of the nuts are partially screwed in. **The Allen Key 2.5mm must be used in a standing position! Otherwise, the mounting screws may crack during tightening!**

Make sure to orientate the backplate as illustrated. Incorrect installation of the backplate may result in damage to the motherboard.

The motherboard backplate can be reused after the water block is secured.

For this step you will need:

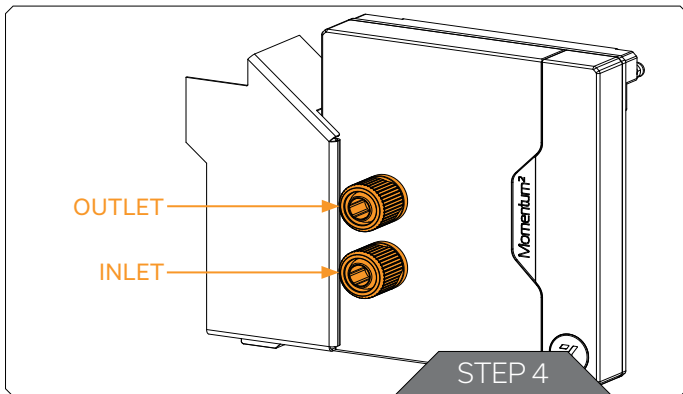
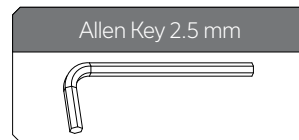

STEP 4

With the **EK-Quantum Momentum² Aorus Z690 Master D-RGB** water block, it is mandatory to use the bottom port as the INLET. Mixing the ports may result in poor thermal performance of the water block.

Tighten the fittings in a clockwise direction until the gasket underneath is compressed.

The installation of the water block is now complete.

CONNECTING THE D-RGB LED STRIP

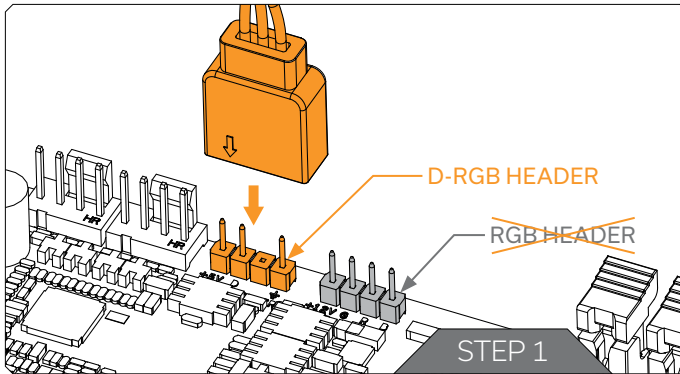

STEP 1

Plug the 3-Pin connector from the water block's D-RGB LED light to the DRGB HEADER on the motherboard. The LED will work if the pin layout on the header is as follows: +5V, Digital, empty, Ground.



Please ensure that the arrow indicated on the connector is plugged into the +5V line as indicated on your motherboard. If you put the LED Diode to the 12V RGB HEADER you can damage the LEDs. Failure to do so will damage your motherboard or LED strip.

TESTING THE LOOP

To make sure the installation of EK components was successful, we recommend you perform a leak test for 24 hours. When your loop is complete and filled with coolant, connect the pump to a PSU outside of your system. Do not connect power to any of the other components. Turn on the PSU and let the pump run continuously. It is normal for the coolant level to drop during this process as air collects in the distribution plate. Inspect all parts of the loop, and in the eventuality, that coolant leaks, fix the issue and repeat the testing process. Ensure that all hardware is dry before the system is powered on in order to prevent any damage.

SUPPORT AND SERVICE

In case you need assistance or wish to order spare parts or a new mounting mechanism, please contact:

<https://www.ekwb.com/customer-support/>

For spare parts orders, refer to the page with "TECHNICAL SPECIFICATIONS AND WATER BLOCK PARTS" where you can find the EAN number of each part you might need.

Include the EAN number with quantity in your request. Mounting Mechanism EAN can be found under "BOX CONTENTS"

Thermal pads are readily available in the EK shop

SOCIAL MEDIA

 EKWaterBlocks

 @EKWaterBlocks

 ekwaterblocks

 EKWBofficial

 ekwaterblocks

