

# Installation and mounting manual for EK-XRES D5 Series Reservoir

This product is intended for installation only by expert users. Please consult with a qualified technician for installation. Improper installation may result in damage to your equipment. EK Water Blocks assumes no liability whatsoever, expressed or implied, for the use of these products, nor their installation. The following instructions are subject to change without notice. Please visit our web site at [www.ekwb.com](http://www.ekwb.com) for updates. Before installation of this product please read important notice, disclosure and warranty conditions printed on the back of the box.

Before you start using this product please follow these basic guidelines:

1. Please carefully read the manual before through before beginning with the installation process!
2. The EK High Flow and EK-PSC type fittings require only a small amount of force to screw them firmly in place since the liquid seal is ensured by the rubber o-ring gaskets.
3. The use of corrosion inhibiting coolants is always recommended for any liquid cooling system.

## STEP 1: PREPARING THE PUMP (already done by EK)

Unscrew the ribbed threaded ring that attaches the Laing pump's original factory top and the main pump core housing with motor. Store the original top, the original o-ring gasket and the attaching ring in a safe place.

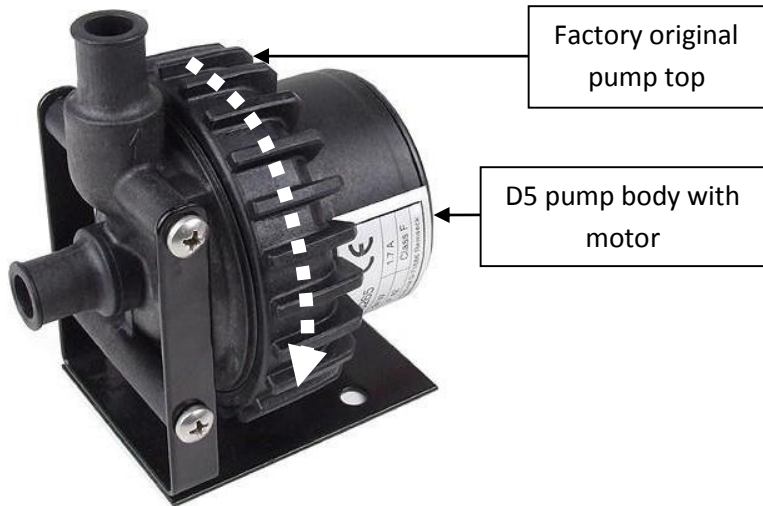

Twist LEFT to unscrew!

## STEP 2: INSTALLING THE XRES D5 (already done by EK)

1. Install the EK-XRES D5S on to the pump main motor housing. **Make sure you install EK provided 61x3mm o-ring gasket!** Reseat the gasket if needed. You can rotate the pump and use it in any direction to best suit your installation.
2. Secure the EK-XRES D5 using enclosed M4x16 DIN7380 screws with the enclosed Allen (hex) key. Do not over tighten the screws as excessive force may strip the threading.

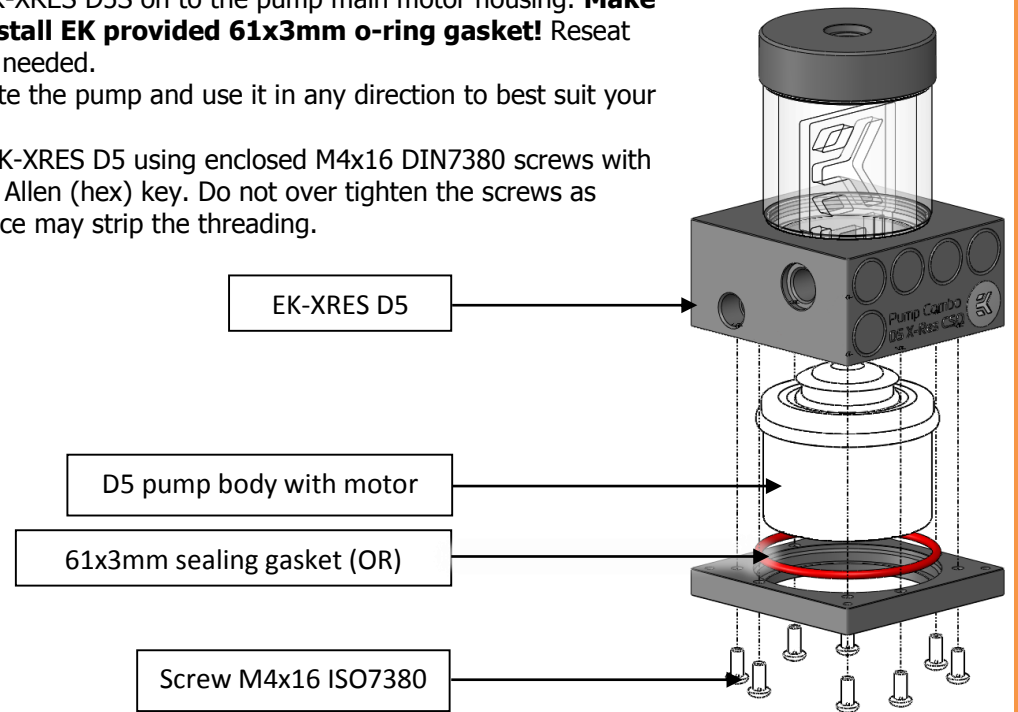

## STEP 3 (optional): USING POLYETHER ANTI-VORTEX FOAM:

EK-XRES D5 series pump top / reservoir comes preinstalled with Anticyclone by default. In case your system suffers from excessive vortex issues, air bleeding problems or if the pump is sucking in air you may replace the anticyclone with the enclosed polyether foam. There are two ways to use the polyether anti-vortex foam:

### Default configuration



This is the default configuration of EK-XRES D5 series reservoir.

### PE foam – use whole



Use the foam as a whole to replace the Anticyclone.

### PE foam – trim to fit recess



Trim the foam to size to fit into the desired inlet recess on the EK-XRES D5 main body.

## STEP 4: MOUNT THE EK-XRES D5 RESERVOIR INTO THE COMPUTER CHASSIS

By default the EK-XRES D5 ships with EK-UNI Holder D5 V2. This holder is meant to be installed directly on the computer chassis. User may need to drill 2 (two) Ø4mm holes through chassis metal using electric power drill if there are no appropriate mounting holes available. EK recommends users to find an appropriate position in your computer chassis to install the EK-XRES D5 pump assembly.

To successfully install the EK-XRES D5 pump/reservoir assembly to the EK-UNI Holder V2 please complete the following steps:

1. Find an appropriate position for the unit inside (or perhaps outside) of your computer chassis; drill mounting holes if needed.
2. Attach the EK-UNI Holder D5 V2 to the computer chassis metal frame using enclosed M4x6 ISO7380 screws, metal washers and a nut. Secure the screws using enclosed Allen key 2.5mm.
3. Screw in the four M4 threaded rubber dampers in to base of EK-XRES D5 pump/reservoir combo unit.
4. Attach the EK-XRES D5 reservoir to the EK-UNI Holder D5 V2 using four (4) M4x6 DIN7380 screws with plastic washers underneath each screw. Secure the screws using enclosed Allen key 2.5mm. Your installation is now complete.

**TIP:** Some users might find installation of the assembly easier if steps 3 & 4 are completed prior to completing step 2.

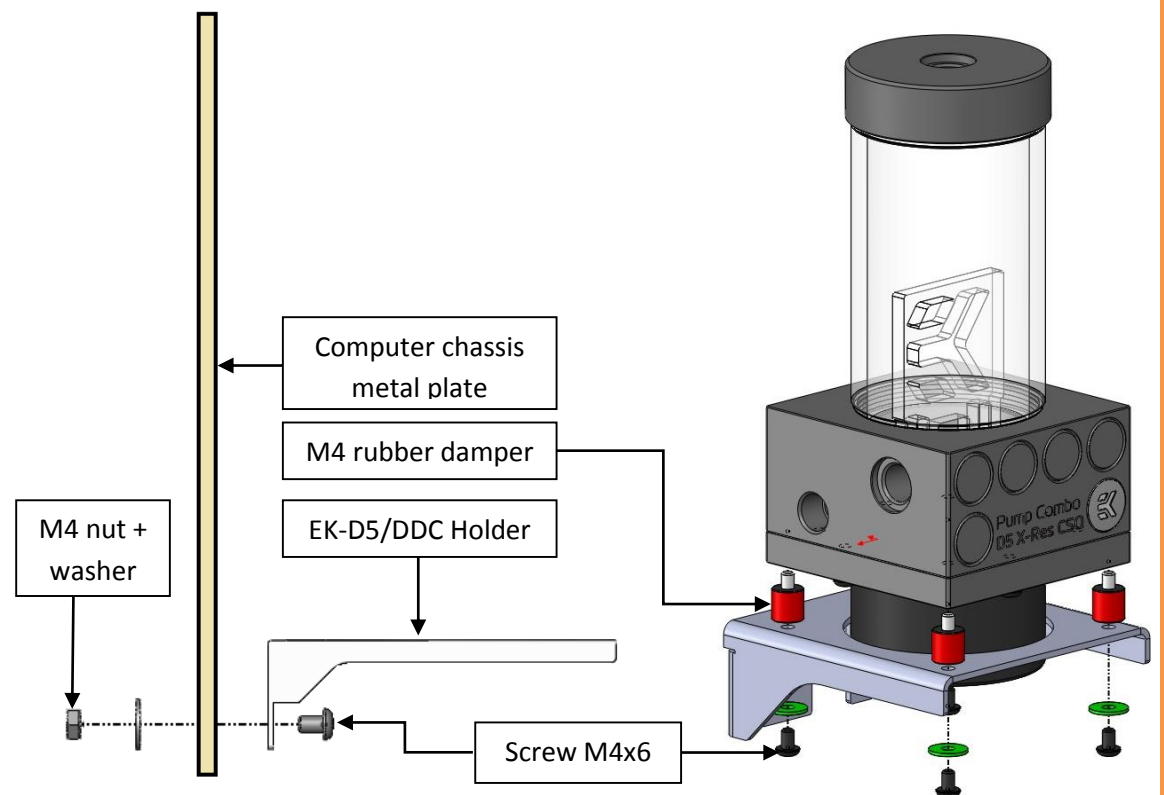

## STEP 5: ATTACHING FITTINGS

EK-XRES D5 series reservoir pump combo featured 3 (three) G1/4 threaded opening on the main body of which 2 (two) are inlets and one is outlet (clearly marked with 'OUT'). EKWB recommends using EK-CSQ fittings with the EK-D5 Vario X-RES CSQ series reservoir pump combo units. To ensure that the tubes are securely attached to the barb/fittings, please use hose clamps or an appropriate substitute.

### It is mandatory to use the correct INLET and OUTLET ports:

1. The OUTLET port (pressure port) is the only port that is not recessed into the plastic housing of the EK-XRES D5.
2. The INLET port(s) (suction port) are the two recessed ports with G1/4 threading on the EK-XRES D5 front face plane. You may use any of these two ports as an INLET port. It is necessary to use the enclosed EK-Extender G1/4 underneath the INLET fitting! Please refer to the picture on the right! **Do not forget to close off the unused INLET port using EK-Plug G1/4!**
3. Make sure not to use fittings or barbs with G1/4 thread longer than 5mm! All *EK-PSC*, *EK-CSQ* and *High Flow* fittings are compatible!

**TIP:** Port on reservoir's top part is not intended to be used as inlet port. The aforementioned port should should only be used for connecting this reservoir with external fill port!

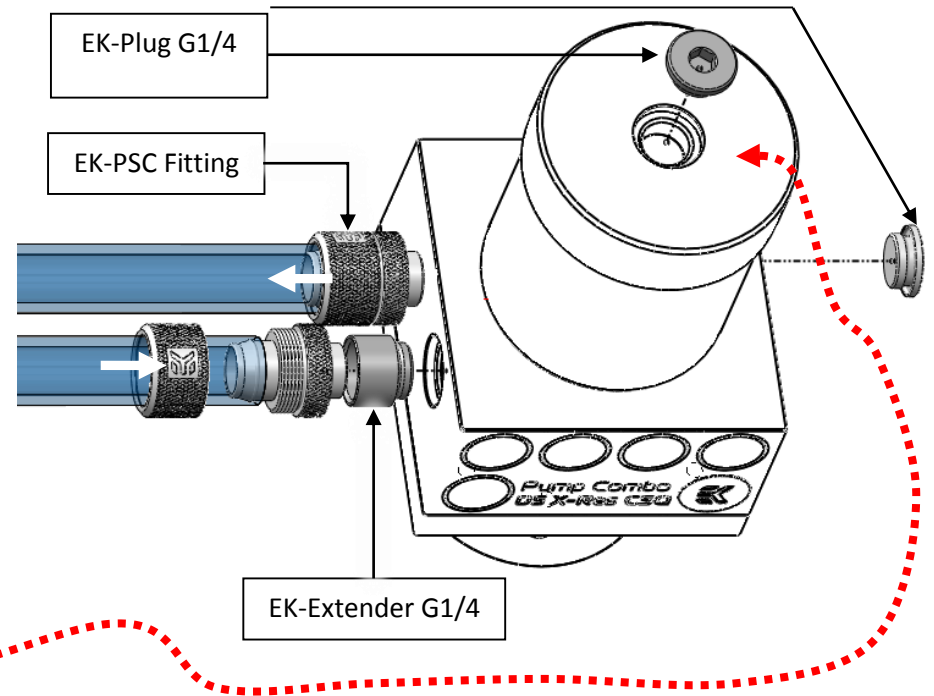

## IMPORTANT DISCLOSURES:

**VERY IMPORTANT NOTICE:** Once the installation is completed, it is a recommended practice to test the cooling circuit for leaks prior to powering up the computer. We recommend a 24 hour leak test prior to powering up the computer. Do not test the water block using tap water pressure. This will rupture the top of the housing and render the block unusable (and will void your warranty). While all efforts have been made to provide the most comprehensive tutorial possible, EK Water Blocks assumes no liability expressed or implied for any consequential damage(s) occurring to your equipment as a result of using EK Water Blocks cooling products, either due to errors or omissions on our part in the above instructions, or due to failure or defect in the EK Water Blocks cooling products.

**WARRANTY:**Our products are warranted against defects in materials or workmanship for a period of 24 months beginning from the date of delivery to the final user. During this period, products will be repaired or have parts replaced at our discretion provided that: (I) the product is returned to the agent from whom it was purchased; (II) the product has been purchased by an end user and has not used for commercial purposes; (III) the product has not been misused, handled carelessly, or used in a manner other than in accordance with the instructions provided describing its installation and proper use. This warranty does not confer rights other than those expressly set out above and does not cover any claims for consequential loss or damage. This warranty is offered as an extra benefit and does not affect your statutory rights as a consumer. This warranty is voided if the product comes in contact with aggressive additives or other improper liquids.

Any other RMA issues can be reported to <http://www.ekwb.com/support> for further analysis.

(this paragraph is intentionally left blank)

## REQUIRED TOOLS



power drill with 4mm drill bit or equivalent (optional)